



High Productivity Cooking thermaline 80 - Freestanding Electric Multi Braiser, 2/1GN, 1 Side, H=800

ITEM # _____

MODEL # _____

NAME # _____

SIS # _____

AIA # _____



Configuration: Freestanding, one-side operated.

588283 (MAADFAHDAO) Electric Multi Braiser, one-side operated, 2/1 GN

Short Form Specification

Item No. _____

Unit constructed according to DIN 18860_2 with 20 mm drop nose top and 70 mm recessed plinth. Internal frame for heavy duty sturdiness in stainless steel. 2 mm top in 1.4301 (AISI 304). Flat surface construction, easily cleanable. THERMODUL connection system enables seamless worktop when units are connected and avoids soil penetrating. Multi-purpose cooking appliance which can be used to shallow fry, cook liquids or as a bain marie. 18 mm-thick stainless steel plated bottom, seamlessly welded to the chrome nickel steel well. Powerblock heating system for optimal temperature distribution, which can be set up to 280°C. Interior pan dimensions allows the use of GN containers. Large drain hole allows to drain the cooking juices into a large collector. All-round basin raised edges to protect against soil infiltration. Overheat protection switches off the supply in case of overheating. Standby function saves energy and quickly recovers maximum power. Metal knobs with embedded hygienic silicon "soft" grip enable easier handling and cleaning. IPX5 water resistant certification.

APPROVAL: _____



Main Features

- Choice of one or two heating zones. An indicator lamp shows operating state of each zone.
- Large drain hole on cooking surface permits the draining of residual cooking juices into a large collector placed under the cooking surface.
- Multi purpose cooking appliance that can be used to shallow fry, cook liquids or even as a bain marie. Unit can be used for sautéing, poaching, steaming, simmering, stewing, braising, boiling and preparing white sauces.
- Overheat protection: the temperature sensor switches off the supply in case of overheating.
- All major components may be easily accessed from the front.
- THERMODUL connection system creates a seamless work top when units are connected to each other thus avoiding soil penetrating vital components and facilitating the removal of units in case of replacement or service.
- Metal knobs with embedded hygienic "soft-touch" grip for easier handling and cleaning. The special design of the controls prevents infiltration of liquids or soil into vital components.
- Powerblock heating system for optimal temperature distribution.
- Raised edge all around the well to protect from infiltration of dirt from worktop.
- Temperature can be set up to a maximum of 280 ° C.
- Interior dimensions of the well enables the use of GN containers.
- Large visible digital display manufactured in tempered glass to resist heat and chemicals, showing temperatures or power settings. The display also shows on/off status of the appliance and on/off status of the heating elements.
- Handles are ergonomically designed with silicon "soft" grip for easy handling and cleaning.

Construction

- An 18 mm thick stainless steel plated bottom is seamlessly welded into the chrome nickel steel well.
- Rounded corners and edges aid cleaning.
- Storage space in the base of the appliance that can accept GN1/1 containers.
- 2 mm top in 1.4301 (AISI 304).
- IPX5 water resistance certification.
- Flat surface construction with minimal hidden areas to easily clean all surfaces
- Unit constructed according to DIN 18860_2 with 20 mm drop nose top and 70 mm recessed plinth.
- Internal frame for heavy duty sturdiness in stainless steel.

Sustainability



- Standby function for energy saving and fast recovery of maximum power.

Optional Accessories

• Lid for multi braisers, 2/1 GN	PNC 910621	<input type="checkbox"/>
• Connecting rail kit, 800mm	PNC 912500	<input type="checkbox"/>
• Stainless steel side panel, 800x800mm, freestanding	PNC 912508	<input type="checkbox"/>
• Portioning shelf, 800mm width	PNC 912526	<input type="checkbox"/>
• Portioning shelf, 800mm width	PNC 912556	<input type="checkbox"/>
• Folding shelf, 300x800mm	PNC 912577	<input type="checkbox"/>
• Folding shelf, 400x800mm	PNC 912578	<input type="checkbox"/>
• Fixed side shelf, 200x800mm	PNC 912583	<input type="checkbox"/>
• Fixed side shelf, 300x800mm	PNC 912584	<input type="checkbox"/>
• Fixed side shelf, 400x800mm	PNC 912585	<input type="checkbox"/>
• Stainless steel front kicking strip, 800mm width	PNC 912598	<input type="checkbox"/>
• Stainless steel side kicking strips left and right, freestanding, 800mm width	PNC 912619	<input type="checkbox"/>
• Stainless steel side kicking strips left and right, back-to-back, 1610mm width	PNC 912625	<input type="checkbox"/>
• Stainless steel plinth, freestanding, 800mm width	PNC 912825	<input type="checkbox"/>
• Connecting rail kit: modular 80 (on the left) to ProThermetic tilting (on the right), ProThermetic stationary (on the left) to ProThermetic (on the right)	PNC 912971	<input type="checkbox"/>
• Connecting rail kit: modular 80 (on the right) to ProThermetic tilting (on the left), ProThermetic stationary (on the right) to ProThermetic (on the left)	PNC 912972	<input type="checkbox"/>
• Endrail kit, flush-fitting, left	PNC 913109	<input type="checkbox"/>
• Endrail kit, flush-fitting, right	PNC 913110	<input type="checkbox"/>
• Scraper for smooth plates	PNC 913119	<input type="checkbox"/>
• Blades with rounded sides for scraper	PNC 913123	<input type="checkbox"/>
• Endrail kit (12.5mm) for thermaline 80 units, left	PNC 913200	<input type="checkbox"/>
• Endrail kit (12.5mm) for thermaline 80 units, right	PNC 913201	<input type="checkbox"/>
• Stainless steel side panel, left, h=800	PNC 913216	<input type="checkbox"/>
• Stainless steel side panel, right, h=800	PNC 913217	<input type="checkbox"/>
• T-connection rail for back-to-back installations without backsplash (to be ordered as S-code)	PNC 913227	<input type="checkbox"/>
• Insert profile D=800mm	PNC 913230	<input type="checkbox"/>
• Perforated shelf for warming cabinets and cupboard bases (one-side operated TL80-85-90 and two-side operated for TL80)	PNC 913234	<input type="checkbox"/>
• Energy optimizer kit 18A - factory fitted	PNC 913245	<input type="checkbox"/>
• Endrail kit, (12.5mm), for back-to-back installation, left	PNC 913249	<input type="checkbox"/>
• Endrail kit, (12.5mm), for back-to-back installation, right	PNC 913250	<input type="checkbox"/>
• Endrail kit, flush-fitting, for back-to-back installation, left	PNC 913253	<input type="checkbox"/>
• Endrail kit, flush-fitting, for back-to-back installation, right	PNC 913254	<input type="checkbox"/>

- Side reinforced panel only in combination with side shelf, for freestanding units PNC 913257
- Side reinforced panel only in combination with side shelf, for back-to-back installations, left PNC 913273
- Side reinforced panel only in combination with side shelf, for back-to-back installation, right PNC 913274
- Shelf fixation for TL80-85-90 one-side operated, TL80 two-side operated PNC 913281
- Filter W=800mm PNC 913665
- Stainless steel dividing panel, 800x800mm, (it should only be used between Electrolux Professional thermaline Modular 80 and thermaline C80) PNC 913669
- Electric mainswitch 25A 4mm² NM for modular H800 electric units (factory fitted) PNC 913676
- Stainless steel side panel, 800x800mm, flush-fitting (it should only be used against the wall, against a niche and in between Electrolux Professional thermaline and ProThermetic appliances and external appliances - provided that these have at least the same dimensions) PNC 913685

Recommended Detergents

- C41 HI-TEMP RAPID DEGREASER, 1 pack of six 1 lt. bottles (trigger incl.) PNC 0S2292

Front

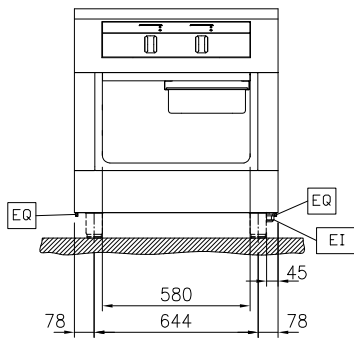

Side

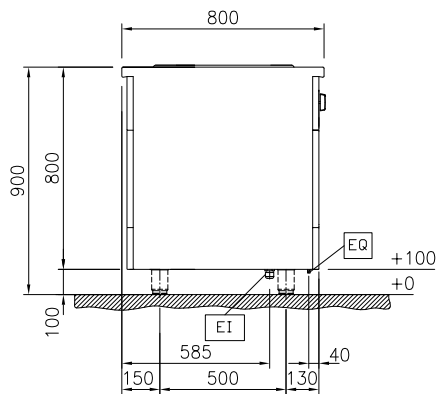

EI = Electrical inlet (power)

Top

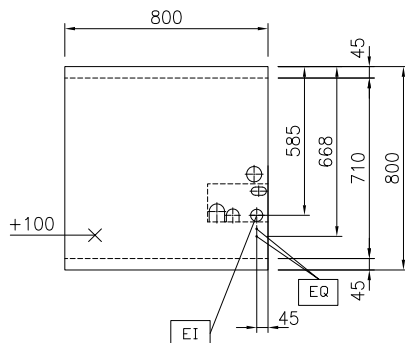

Electric

Supply voltage:	400 V/3N ph/50/60 Hz
Total Watts:	10.2 kW

Key Information:

Usable well dimensions (width):	630 mm
Usable well dimensions (height):	110 mm
Usable well dimensions (depth):	510 mm
Cooking Well Height:	110 mm
Well Capacity, Max:	22 lt
Working Temperature MIN:	80 °C
Working Temperature MAX:	280 °C
External dimensions, Width:	800 mm
External dimensions, Depth:	800 mm
External dimensions, Height:	800 mm
Storage Cavity Dimensions (width):	580 mm
Storage Cavity Dimensions (height):	330 mm
Storage Cavity Dimensions (depth):	740 mm
Net weight:	140 kg
Configuration:	Rectangular;Fixed

Sustainability

Current consumption:	14.7 Amps
----------------------	-----------

Optional Accessories

- Lid for multi braisers, 2/1 GN PNC 910621
- Connecting rail kit, 800mm PNC 912500
- Stainless steel side panel, 800x800mm, freestanding PNC 912508
- Portioning shelf, 800mm width PNC 912526
- Portioning shelf, 800mm width PNC 912556
- Folding shelf, 300x800mm PNC 912577
- Folding shelf, 400x800mm PNC 912578
- Fixed side shelf, 200x800mm PNC 912583
- Fixed side shelf, 300x800mm PNC 912584
- Fixed side shelf, 400x800mm PNC 912585
- Stainless steel front kicking strip, 800mm width PNC 912598
- Stainless steel side kicking strips left and right, freestanding, 800mm width PNC 912619
- Stainless steel side kicking strips left and right, back-to-back, 1610mm width PNC 912625
- Stainless steel plinth, freestanding, 800mm width PNC 912825
- Connecting rail kit: modular 80 (on the left) to ProThermetic tilting (on the right), ProThermetic stationary (on the left) to ProThermetic (on the right) PNC 912971
- Connecting rail kit: modular 80 (on the right) to ProThermetic tilting (on the left), ProThermetic stationary (on the right) to ProThermetic (on the left) PNC 912972
- Endrail kit, flush-fitting, left PNC 913109
- Endrail kit, flush-fitting, right PNC 913110
- Scraper for smooth plates PNC 913119
- Blades with rounded sides for scraper PNC 913123
- Endrail kit (12.5mm) for thermaline 80 units, left PNC 913200
- Endrail kit (12.5mm) for thermaline 80 units, right PNC 913201
- Stainless steel side panel, left, h=800 PNC 913216
- Stainless steel side panel, right, h=800 PNC 913217
- T-connection rail for back-to-back installations without backsplash (to be ordered as S-code) PNC 913227
- Insert profile D=800mm PNC 913230
- Perforated shelf for warming cabinets and cupboard bases (one-side operated TL80-85-90 and two-side operated for TL80) PNC 913234
- Energy optimizer kit 18A - factory fitted PNC 913245
- Endrail kit, (12.5mm), for back-to-back installation, left PNC 913249
- Endrail kit, (12.5mm), for back-to-back installation, right PNC 913250
- Endrail kit, flush-fitting, for back-to-back installation, left PNC 913253
- Endrail kit, flush-fitting, for back-to-back installation, right PNC 913254

- Side reinforced panel only in combination with side shelf, for freestanding units PNC 913257
- Side reinforced panel only in combination with side shelf, for back-to-back installations, left PNC 913273
- Side reinforced panel only in combination with side shelf, for back-to-back installation, right PNC 913274
- Shelf fixation for TL80-85-90 one-side operated, TL80 two-side operated PNC 913281
- Filter W=800mm PNC 913665
- Stainless steel dividing panel, 800x800mm, (it should only be used between Electrolux Professional thermaline Modular 80 and thermaline C80) PNC 913669
- Electric mainswitch 25A 4mm² NM for modular H800 electric units (factory fitted) PNC 913676
- Stainless steel side panel, 800x800mm, flush-fitting (it should only be used against the wall, against a niche and in between Electrolux Professional thermaline and ProThermetic appliances and external appliances - provided that these have at least the same dimensions) PNC 913685

Recommended Detergents

- C41 HI-TEMP RAPID DEGREASER, 1 pack of six 1 lt. bottles (trigger incl.) PNC 0S2292